

Curved door with flat glass panes

BY CLARK KELLOGG



A curved or bow-front feature gives a sophisticated look to any piece of furniture. The downside of adding glass is the high price of curved panes. I learned a good compromise at the College of the Redwoods, where founder James Krenov developed a straightforward technique for setting straight panes into curved rails. And I have continued to use it.

This technique isn't difficult. The curved door rails are laminated over a bending form. Then, a rabbet with three facets is routed into the back of the rails and the glass panes are set into them.

Make the door frame first

As with any curved door, it is far easier to fit the cabinet to the door

than the other way around, so start with the curved rails. I make mine by laminating $\frac{1}{8}$ -in.-thick plies over a bending curve.

After the rails have been laminated, joint one edge and then rip them to width. Next, use one of the rails to make a full-size, top-view drawing of the door. Lay out the precise locations of the bridle joints, mullions, glass panes, and stops. Use the drawing to mark the final length of the rails and then cut them.

Now you can cut the slots for the bridle joints in the rails. I use a tenoning jig and my tablesaw. Because the rail is curved, I make a cradle for the jig to hold it so that the slot is cut parallel to its sides. Then I head over to the bandsaw and rip off a $\frac{1}{8}$ -in.-thick strip from the top edge of the bottom rail and from the bottom edge of the top rail. These strips are used later to make stops to hold the glass in the door.

The stiles are next. Make them slightly wider and thicker than their final

TAKE STRAIGHT GLASS AROUND THE BEND

The trick is to use multiple panes and set them into straight rabbets routed into the back of the curved rails.

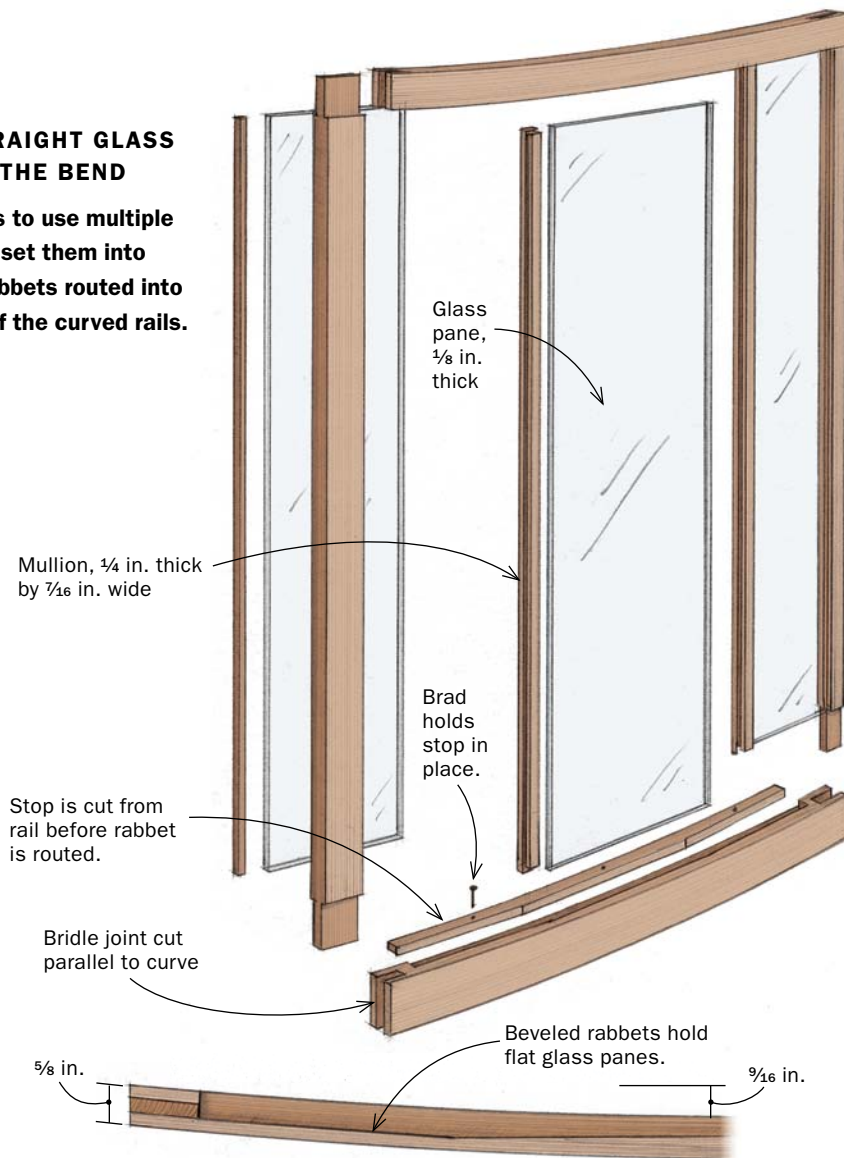

dimensions. The extra thickness lets you plane them to match the curve of the rails, and the extra width helps with the clamping when you're gluing the door together. After they are cut, dry-fit the frame and plane the stiles to match the rails' curve.

Rout the rabbets for the glass panes

The glass panes fit into the door using rabbets, but because the glass is flat, the rabbets must be faceted. I use a jig to rout them.

Start by making a template of the faceted rabbet. And then use that template to make the jig (see photos, p. 92).

After the jig is made, rout the rabbets and then hold the rails against one another to check that they are mirror images of one another. If there are any differences between the rabbets, shim one of the registration blocks with tape and rerout the rabbets.

Next, rout the rabbets in the stiles. In order for this rabbet to be square to the one in the rail, you need to use a simple jig. Glue a shim (I use a few pieces of veneer) along the length of a piece of MDF. Use double-stick tape to attach this jig to your router table (shim side down) and then rout the rabbets by running the

Laminate the curved rails

The grain of the plies follows the curve, so the rails are stronger than if they were cut from a solid blank. Also, the curve of the top and bottom rail is more likely to be the same. That's important, because deviations between them can result in cracked glass.



Spread the pressure evenly. Kellogg uses blocks under the clamp head and three hardboard cauls to ensure that all of the glue joints are tight.



Cut the slots at the table-saw. Add a cradle to your tenoning jig, curved to match the rail, to hold the rail at the correct angle.

Jig creates straight rabbets on curved rails

The rails on this door are curved, but the three glass panes are straight. That means the rabbets they sit in must have three straight sides. This jig is the best way to rout them.



Build a template first. It's used to make the jig. Do it over a full-size drawing so that it fits your rails perfectly. Align the first piece with the straight side of the rabbet for the middle pane.



Shims create the other sides. Use solid wood for these (left), so you can easily tune their shape with a handplane to match the drawing. Glue them in place with cyanoacrylate glue. Use stops to end the rabbets (right). If they ran through the rails, they'd be seen after the door is glued up.



Use the template to make the jig. Kellogg roughs out the shape on a piece of 3/4-in.-thick MDF, screws the template to the MDF, and then routs it flush to the template.

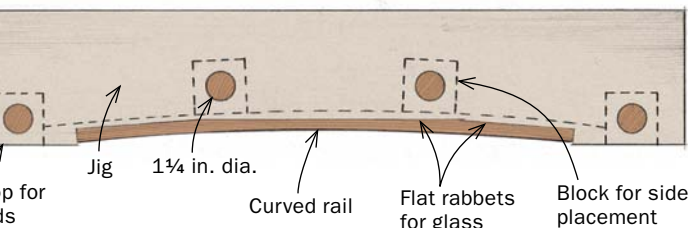

MAKE THE JIG REVERSIBLE

The rabbets in the top and bottom rails need to mirror each other perfectly. Since the template probably isn't perfectly symmetrical, you can't just flip the workpieces in the jig. Instead, you rout them from opposite sides of the jig, moving the registration blocks to the other side.

Flip block and insert from opposite side to rout second rail.

Turn tenon to fit hole.

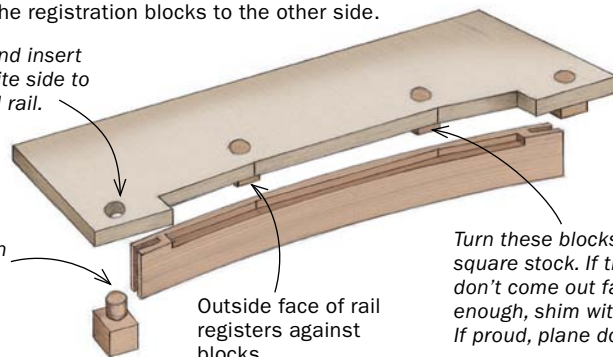

Outside face of rail registers against blocks.

Turn these blocks from square stock. If they don't come out far enough, shim with tape. If proud, plane down.

stile on top of the jig and taking several light passes.

Make the mullions and stops

Glue up the frame. After the glue has dried, square up the corners of the rabbets with a chisel. Then make the mullions. I cut them a hair too long and use a shooting board and plane to sneak up on a perfect fit. Notch the ends so that they just fit over the rabbets. I do that at the tablesaw with a crosscut sled.

Next, rout 1/8-in.-thick slots in both sides of the mullions. Like the rabbets in



Rout the rabbet. A guide-bushing rides on the jig. Kellogg uses a 1/2-in.-dia. spiral downcut bit to eliminate tearout on the top of the rabbet. He squares up the corners of the rabbets after the frame is glued up.

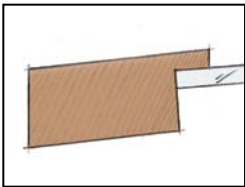

Rabbet the door stiles

Now that the big challenge—the rails—is out of the way, finish the door by rabbeting the stiles and then gluing together the door frame.

ANGLE THE RABBET IN THE STILES

That keeps it perpendicular to the curve of the door and allows the glass to sit flat on its bottom.

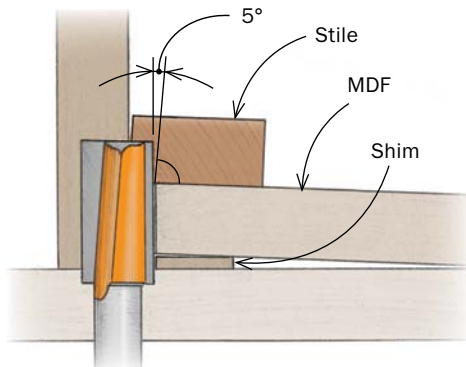

A shim does it. A shim glued to the underside of a piece of MDF lets you rout the angled rabbets with a straight bit.



Clamp bridle joints from three directions. Go across the width and down the length and then add a clamp to press the sides of the slot tight against the tenon.

the stiles, these slots need to be slightly angled in order to be square to the rabbets in the rails. Use the same jig you used for the stiles (but with a thinner shim) and a slot-cutting bit. Leave at least $\frac{1}{8}$ in. of material between the slots.

Dry-fit the mullions into the door and measure for the glass panes. Cut them about $\frac{1}{16}$ in. undersize on all four sides.

Now take the thin offcuts from the rails (the ones you cut at the bandsaw before rabbeting the rails) and make the stops for the rails. Clean up any saw marks and notch them to fit around the mullions. Next, make straight stops for the stiles. The stops are held in place with small brass pins. Remove the glass from the frame, locate holes for the pins (four or five per stop), and drill them in the stops and frame.

Reassemble the door with glass, mullions, and stops. Gently press the pins into place with a small wood block. Tap the glass to make sure it doesn't rattle in place. Finally, disassemble the door and store the parts in a safe place while you make the rest of the cabinet. After the case is built, fit the door frame, mortise the hinges, and apply a finish. Reassemble the door and hang it. □

Clark Kellogg is a furniture maker in Houston, Texas.

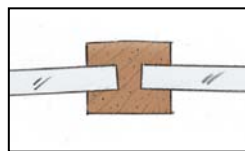

Make the mullions

Grooved mullions separate the panes from one another, and the glass stops hold them in the rabbets.

MULLION GROOVES ARE ANGLED, TOO

The angle is a bit smaller than the one in the stiles, so the shim needs to be thinner. Notch the mullion to fit the rails.

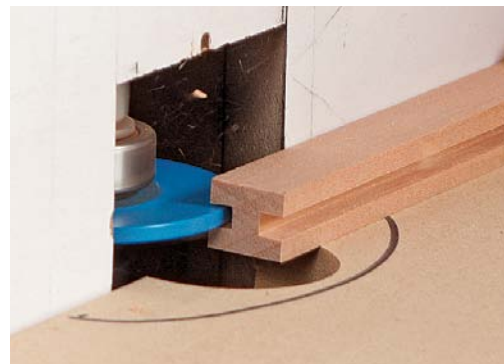
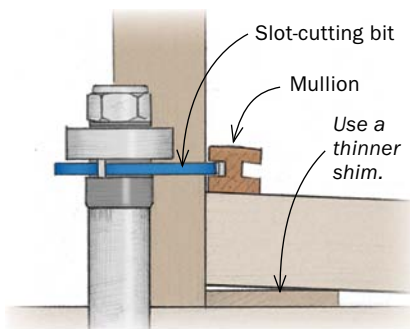

Make a new jig. The angle is smaller on the mullions, so the shim needs to be thinner.

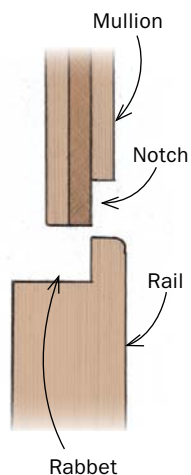

Fine-tune the fit. Dry-fit the mullions and mark for a notch that brings them flush with the front of the rails.



Add the stops. They were cut from the rails earlier. Drill clearance holes for the pins that hold them in place. Push them in with a wood block, protecting the glass with cardboard.